

Bell System
Technical Journal
Vol XVI
April 1937

Sound Recording on Magnetic Tape

By C. N. HICKMAN

This paper describes an improved method of recording sound magnetically on a steel tape, similar in principle to that of the Poulsen telegraphone. In the latter a longitudinal magnetic pattern of the voice current is imprinted on a steel wire by drawing it rapidly past recording pole pieces. The high speed used by Poulsen and subsequent investigators has been directly and indirectly a limiting factor in the application of magnetic recording to commercial uses. The system here described makes use of perpendicular magnetization. This method makes it possible, with suitable equalization, to obtain a substantially uniform frequency-response characteristic up to 8000 cycles per second with a tape speed of only 16 inches per second. In many cases a speed of 8 inches per second is adequate for recording speech. At the same time the ratio of signal to background noise has been substantially increased.

The decrease in efficiency resulting from the use of perpendicular instead of longitudinal magnetization is offset to a great extent by the use of a better design and construction of the pole-pieces and a more suitable recording medium. The recording medium is a steel tape having a thickness of about 1.0 to 2.0 mils (0.025 to 0.051 mm.) and a width of about 50 mils (1.3 mm.).

INTRODUCTION

A SYSTEM of recording speech magnetically on a steel wire was invented by Poulsen almost forty years ago. The wire was drawn past a pair of pole-pieces surrounded by coils carrying a speech current. A magnetic pattern corresponding to the current was thus impressed on the wire. When the wire thus magnetically treated was again drawn past the pole-pieces a current corresponding to the recording current was induced in the surrounding coils. It was common practice to place the pole-pieces on opposite sides of the wire and offset with respect to each other. The magnetic pattern in the wire thus consisted mainly of a variation in the intensity of magnetization, the direction of the magnetization being substantially parallel to the axis of the wire. This method of putting the record on the wire is known as longitudinal magnetization. With such a system the wire must travel at a very high speed if high frequencies are to be recorded and reproduced. It was customary to use speeds of from six to ten feet per second. By using tape instead of wire, the recording and re-

producing pole-pieces may be placed directly opposite each other so that the magnetic pattern consists of variations in the intensity of magnetization, the direction of the magnetization being substantially perpendicular to the surface of the tape. This type of magnetization will be called perpendicular magnetization. There is another method of recording in which the magnetization is in a direction perpendicular to an edge and parallel to the surface of the tape which has been called cross or transverse magnetization.

In spite of the fact that the principle of magnetic recording has been known for a long time, there has been very little literature on the subject until recently. Several papers¹ which deal almost entirely with the longitudinal method of magnetization have been published abroad during the past two years. Cross magnetization is discussed briefly in one of the papers. Apparently, perpendicular magnetization has not been seriously considered. This paper will treat mainly the perpendicular method of magnetization with which a good frequency-response characteristic may be obtained with a tape speed of only 16 inches per second.

FORMS OF RECORDING MEDIA

Steel wire has been used as a recording medium in most of the telegraphones. This was probably because it was easier to obtain. When wire is used it is necessary to make the longitudinal separation of the pole-pieces rather large. This is done in order to minimize the distortion caused by the continual rotation of the wire about its axis. Such rotations change the relation of the magnetic patterns in the wire with respect to the reproducing pole-pieces from that which existed at the time the record was made.

When the pole-pieces have a wide separation, high linear speed must be used in order to record and reproduce high frequencies. The high speed required in this method of recording gives rise to a number of mechanical difficulties. The contacting pole-pieces wear away rapidly and it is difficult if not impossible to construct and hold them so that they will ride smoothly against the wire. These variations in contact with the wire change the magnetic reluctance of the flux path so that the signal strength varies and an excessive amount of noise is introduced.

Recording on steel discs has been investigated from time to time but no practical results have yet been reported.

¹ See list at end of this article of recently published papers dealing with magnetic recording.

Steel tape as a recording medium was suggested by V. Poulsen in his U. S. patent No. 661,619-1900. Its use eliminates many of the objectionable features of the wire recording system. The magnetic patterns in the tape pass the pole-pieces during reproducing in the same relative positions as at the time they were made. It is practical to wind the tape on reels of pancake shape. Snarling difficulties encountered when using wire are thereby avoided. Thin tape permits the use of smaller pulleys without exceeding the bending fatigue limit of the metal. The use of tape permits the perpendicular method of magnetization to be employed. High frequencies may therefore be recorded and reproduced with a relatively low linear tape speed.

METHODS OF MAGNETIZATION

There are two methods of longitudinal magnetization in use, one and two pole-piece recording. A detailed description of these methods is given in two of the papers which have been mentioned. It will be sufficient here to consider them only briefly.

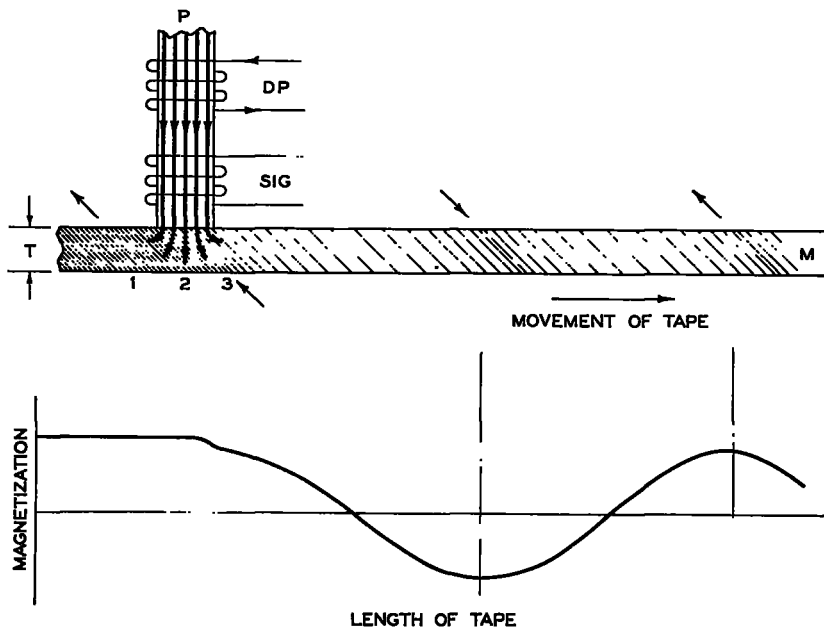

Fig. 1—Longitudinal magnetization of a recording medium by a single pole piece.
SIG = Signal coil; DP = Depolarizing coil.

Figure 1 shows the action taking place in recording with one pole-piece. *M* is the recording medium and *P* is the recording pole-piece.

It will be assumed that the recording medium has been previously magnetized by drawing it past a pole-piece so that the residual magnetization in it has a direction as indicated by the upper arrow at the left.² In this method of recording the magnetization is principally parallel to the axis of the medium but in order to simplify the drawing, the direction of magnetization in Fig. 1 is shown at a considerable angle. If the pole-piece *P* carries a steady flux in the direction indicated by the heavy lines, this flux will spread in the medium. At the point 2 in the middle of the pole-face, the flux will be substantially perpendicular to the axis of the medium. On either side it will be approximately parallel to the axis of the medium but of opposite directions. As the elements of the recording medium approach the pole-piece *P*, they will first be subjected to the flux 1 which is in approximately the same direction as the residual magnetization in the medium so that no appreciable change will take place. When the elements are directly opposite the face of the pole-piece they will be acted on by a flux 2 which is nearly perpendicular to the residual magnetization of the medium. When the elements reach the position 3, the flux will be in opposition to the original magnetization within the medium. If it were not for these changes in the direction of the flux while the elements are passing from the position 1 to the position 3 a signal record without appreciable distortion could be left on the medium at the point 3 by superimposing a signal flux on the steady flux in the pole-piece *P*. It will be realized that the positions 1, 2 and 3 are not discrete points but that they cover an appreciable distance. The spreading of the flux at 3 will be considerable so that it will be necessary for the medium to travel at high speed in order to get the recorded signals away from the recording flux before the record is distorted by subsequent signals.

Figure 2 shows a similar diagram for two pole-piece recording. Where two pole-pieces are relatively close to each other, the flux will not spread so much in the medium and the direction of magnetization will be approximately the same as that of the recording flux. It is again assumed that the residual magnetization within the medium is mainly in the opposite direction to the motion of the medium as indicated by the upper arrow at the left. The flux 1 will have no appreciable effect on the residual magnetization. The flux 3 is in the opposite direction to the residual magnetization and were it not for

² In Figs. 1, 2, 3, 4 and 6, the heavy lines passing through the pole-pieces represent the instantaneous recording flux. The density of the fine lines in the recording medium represents the intensity of magnetization. The arrows above and below the medium show the direction of this magnetization. The curve below represents the nature of the signal that has been recorded on the tape.

these changes in the direction of the flux while passing from 1 to 3, a modulation of the flux 3 might be expected to leave an undistorted record on the medium as was the case with one pole piece recording. However, in the case of two pole-pieces, the elements still must pass the pole-piece P_2 where the flux 4 is approximately perpendicular to the medium. After passing the pole-piece P_2 the record is subjected to the flux 5 which is in the opposite direction to the recorded flux. The record which was made by the flux 3 is therefore distorted by fluxes 4 and 5. This distortion is greater than it is for one pole-piece

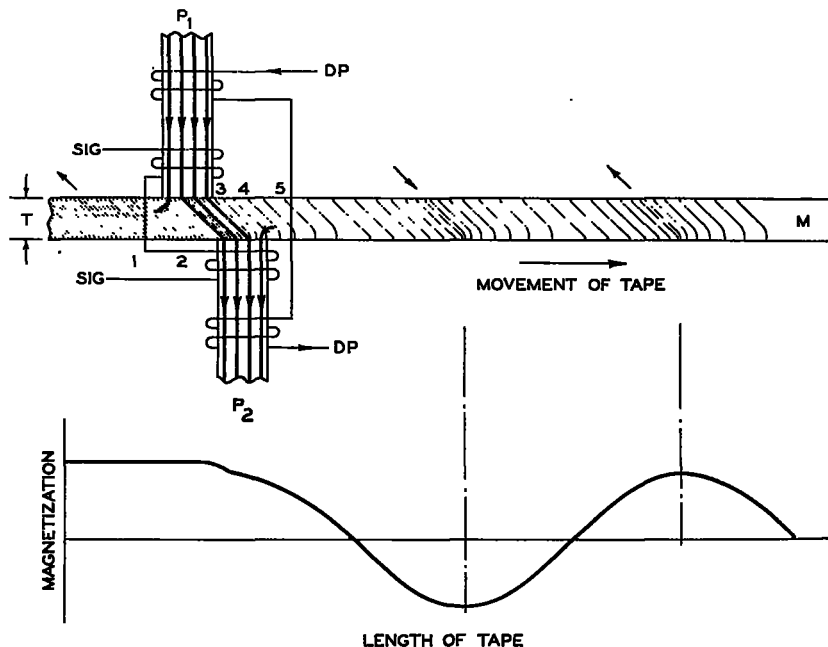

Fig. 2—Longitudinal magnetization of a recording medium by two pole pieces.

recording. In practice the stray fluxes 4 and 5 are sufficiently small so that the distortion introduced may be tolerated in exchange for the improved frequency response which is obtained with two pole-piece recording.

Figure 3 shows the action taking place where cross-magnetization is used. It is here assumed that the recording medium has been previously magnetized so that the residual magnetization is in the direction indicated by the upper arrows at the left. W represents the width of the recording medium which in this case is a steel tape. It will readily be seen that if W is very large there will be considerable spread-

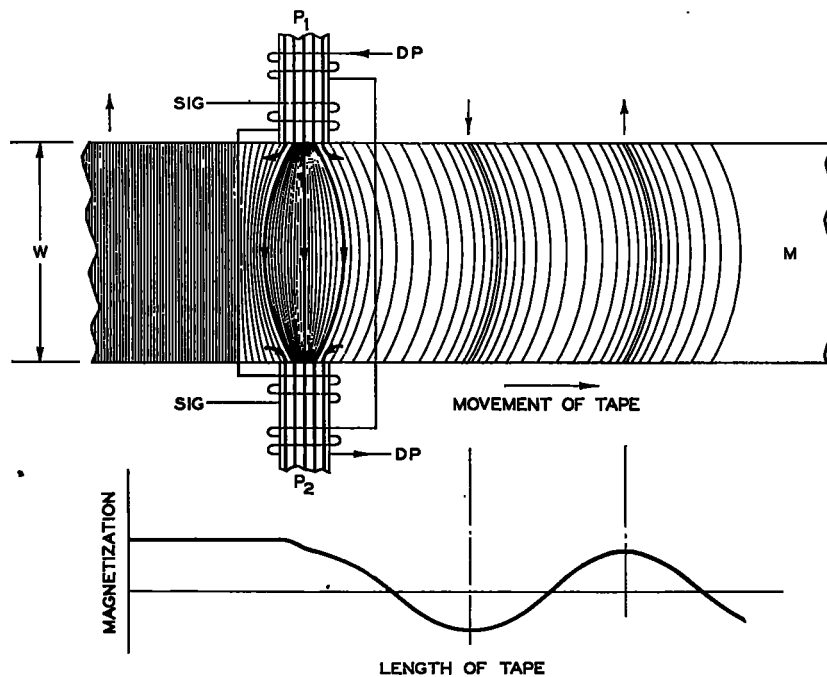

Fig. 3—Transverse magnetization of a steel tape.

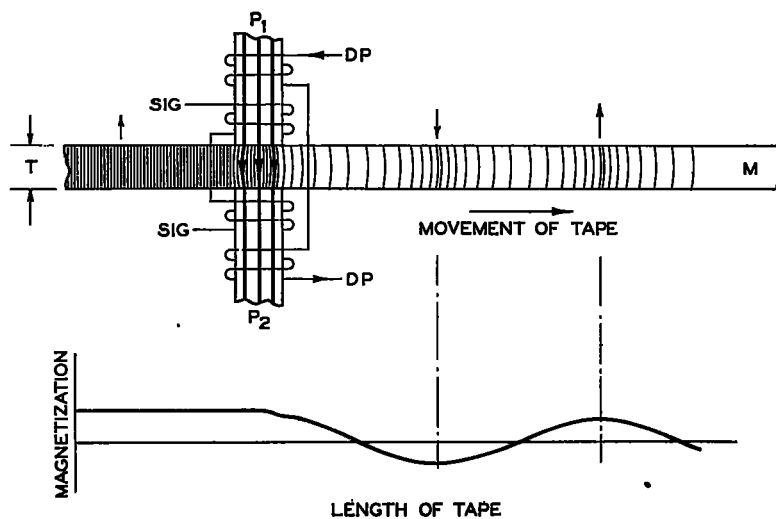

Fig. 4—Perpendicular magnetization of a steel tape.

ing of the recording flux within the tape. The recording flux is always at substantially right angles to the axis of the tape and parallel to its surface and is in the opposite direction to the residual magnetization.

If W is made quite small or in other words if the pole-pieces P_1 and P_2 are directly opposite each other with the thin dimension of the tape between them, we have the conditions shown in Fig. 4. The tape is so thin that there is very little spreading of the flux so that the width of the flux path is not appreciably dependent on the strength of the signal. This type of recording is called perpendicular magnetization in order to distinguish it from cross-magnetization, where the width of the tape instead of the thickness determines the pole-piece separation. The perpendicular method of magnetization permits a relatively low tape speed. The thickness of the pole-piece tips determines the frequency response for a given tape speed.

Method of Recording with Perpendicular Magnetization

If the tape is first subjected to a saturation flux which is at right angles to the surface of the tape, it will be left with one side of north and the other of south polarity. If the tape in this condition is passed between recording pole-pieces carrying only AC flux, it is obvious that only half cycles will be recorded. The record is therefore much distorted. The current reproduced from such a record is similar to the alternating current which may be obtained from a single wave rectifier.

If on the other hand the tape is passed through an alternating high-frequency field which is strong enough to erase the record, it is left in a substantially neutral condition. If it is then passed between the recording pole-pieces, both half cycles will be recorded but there will be amplitude distortion. Figure 5 shows a magnetization curve for iron which has previously been demagnetized with alternating current. The slope of the first part of the curve is small in either direction of magnetization and then increases with increase in the flux and finally becomes smaller again. Small signals will therefore be recorded weakly and strong signals will be recorded relatively higher. Both will have wave form distortion. The same effects would be obtained with longitudinal or cross magnetization. In the past, investigators have often utilized only one side of the magnetization curve. A direct current was used as a bias to bring the recording flux to the most suitable part of the curve such as at n , Fig. 5.

The method employed here will be made clear from Figs. 6 and 7. As the tape elements enter the field of the polarizing pole-pieces P_1 , P_2 (Fig. 6) they are subjected to an increasing magnetizing force. The

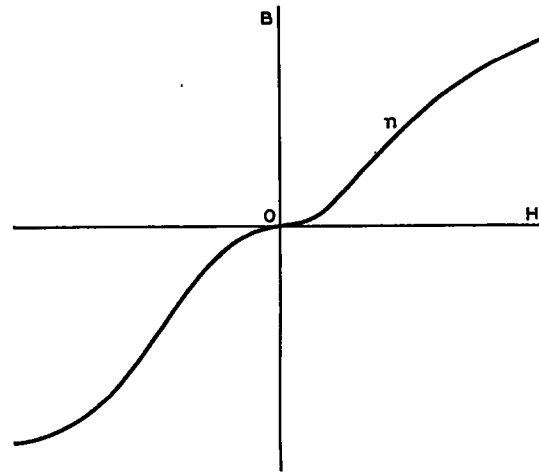

Fig. 5—Typical magnetization curve for steel.

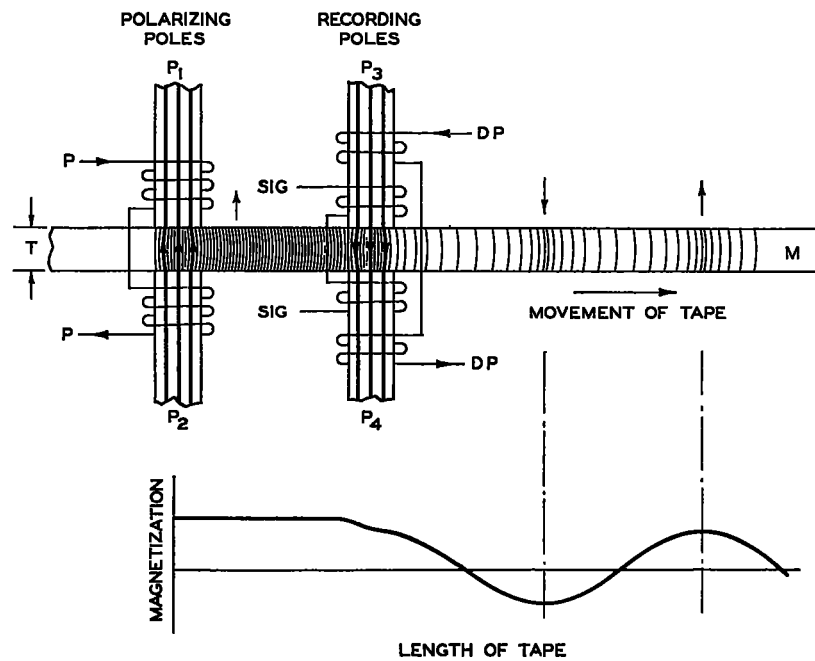

Fig. 6—Perpendicular magnetization method of recording on steel tape.
 SIG = Signal coil; P = Polarizing coil; DP = Depolarizing coil.

elements are magnetized to the saturation point P as shown by curve a , Fig. 7. As the elements leave the polarizing field they are subjected to a field of decreasing strength so that the magnetic induction drops along the curve b to R , this point being reached when the applied field is zero. In Fig. 7, the magnetizing force H refers to the externally applied field. The tape elements then pass between the recording pole-pieces which carry a flux in opposite direction to that of the polarizing pole-pieces. If there is no signal current present, the magnetic induction will be brought down to the point N by the biasing field. As the elements pass out from between the pole-pieces, the field will decrease to zero and the magnetic induction will change from

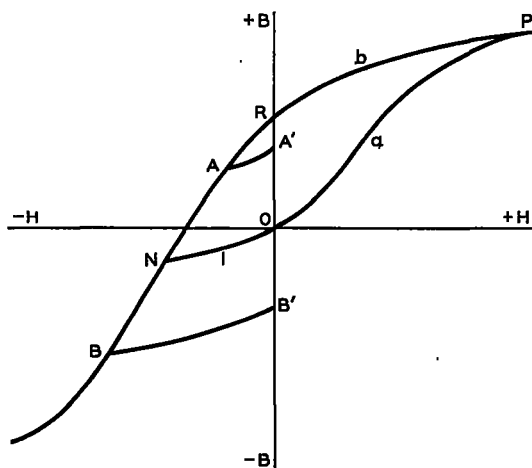

Fig. 7—Diagram showing the cycles of magnetization through which the elements of a steel tape may pass during the process of recording.

N to O , which is a substantially neutral condition. However, if there is a signal current present at the time the tape elements are passing between the recording pole-pieces, the magnetization will be reduced to a point A higher than N if the cycle is in opposition to the bias flux or to the point B lower than N if the signal flux is in the same direction as the bias flux. In either case the elements will retain a magnetization value corresponding to A' or B' respectively. This system makes it possible to record over a longer portion of the magnetization curve without appreciable distortion.

Unless the proper value of biasing field is used to bring the magnetization approximately to the point N when no voice current is present, the maximum recording range cannot be obtained without excessive amplitude distortion. For example if no bias is used, it has been found

that the output plotted against input will be too steep as shown in the curve 1, Fig. 8. If the bias is too great, the output input curve will be inclined too much as shown in curve 2 of the same figure. When the

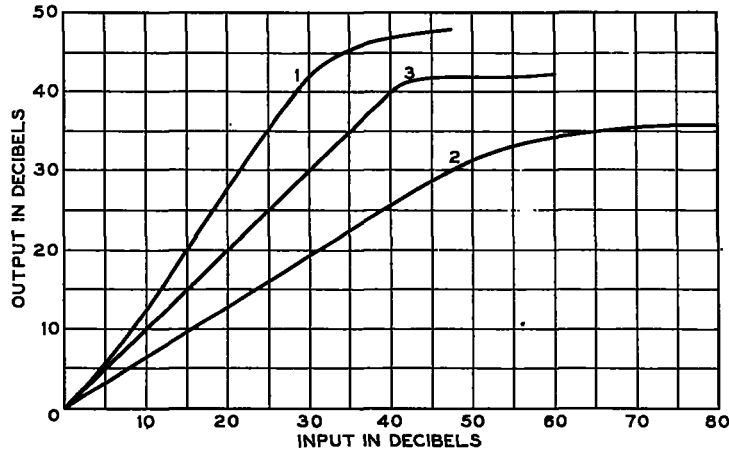

Fig. 8—The effect of the biasing current on the slope of the output-input level curves.

proper value of bias is used the curve 3 is obtained which is inclined at 45 degrees. Measurements of output versus input may therefore be used to determine the proper bias current.

Another method of determining the proper amount of bias is to plot the output obtained from records of very weak signals as a function of

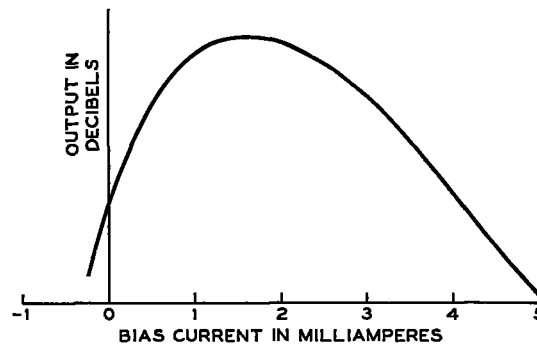

Fig. 9—Effect of the biasing current on the intensity of weak signals.

the bias current used during recording. Figure 9 shows such a curve for a 1000-cycle record. In selecting the proper bias current from the curve, the point at the crest gives the most efficient value but it is

better to favor some point slightly to the right of the crest in order to avoid the danger of very strong signals operating too far down on the left side of the curve. The recording current for the 1000 cycles had a value 30 db below the overload so that only a small amplitude was used in obtaining the data for this curve.

If the same set of pole-pieces is used both for recording and reproducing, there is no question of getting the reproducing pole-pieces in the same alignment as the recording pole-pieces. If different sets are used care must be taken to get the same alignment.

In order to keep the signal high above the tape noise, it is desirable to record so that the flux or current amplitude is independent of the frequency. Since the impedance of the recording coils rises rather sharply with frequency, it is necessary either to place a high resistance in series with the recording coils or to connect them to a high impedance. The later method is of course the more efficient. Since the energy present in the higher frequencies of voice and music is usually less than in the 1000-cycle region, an amplifier having a rising characteristic may be used in order to record these frequencies at a higher level. A corrective network may be used in reproducing to obtain the desired frequency response. Such a procedure increases the apparent ratio of signal to the tape noise.

REPRODUCING

If the thickness of the pole-piece tips is small with respect to the wave length of the signal on the tape, the voltage generated in the reproducing coils is proportional to frequency, so that the coils may be matched to favor the lower frequencies. If a straight line frequency characteristic is desired, a corrective network may be used.

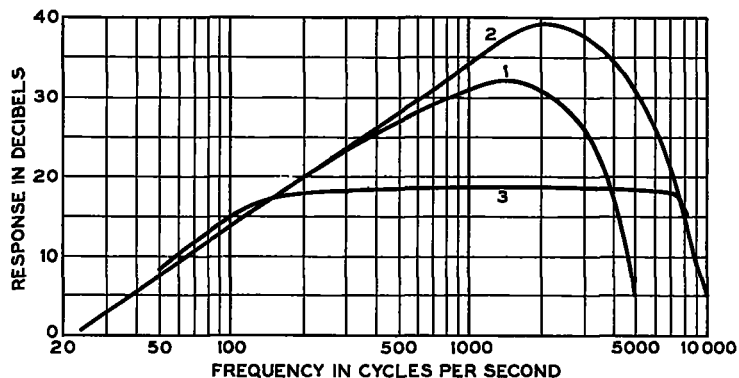

Fig. 10—Frequency response curves obtained with the perpendicular method of magnetization.

Figure 10 shows several frequency response curves. Curve 1 shows a response without the use of equalization for a tape speed of 8 inches per second. Curve 2 shows the response under the same conditions for a tape speed of 16 inches per second. Curve 3 shows the same signals of curve 2 reproduced through a suitable equalizer.

The ratio of the maximum reasonably undistorted 1000-cycle signal to the noise with typical good tape is about 38 db. The transfer loss is approximately 60 to 70 db. The maximum power required in recording is about 0.3 milliwatt.

CHARACTERISTICS OF MAGNETIC RECORDING

Magnetic recording differs from other methods in several respects. Since no processing is required, the record may be reproduced without a long delay. The recording medium may be used over and over again for new records. It is only necessary to subject the tape to a strong magnetic field in order to obliterate a record. The obliteration is conveniently done at the same time that the new record is being made. Where temporary records are desired, magnetic recording therefore has some advantages over other methods. On the other hand it should be fully appreciated that the records may be kept, filed away, or reproduced thousands of times with no appreciable deterioration in the quality.

The magnetic system is very convenient for use where short delays are desired. A short loop of tape in conjunction with recording, reproducing, and obliterating pole-pieces is all that is required. Instead of a loop of tape, a disc or cylinder rotating at high speed may be used to carry the recording medium. The latter method makes it possible to obtain very short delays. Where perpendicular magnetization is used, very long records may be obtained from a medium which occupies a relatively small amount of space. For example, a thin coil of 2 mil tape 9 inches in diameter will give a playing time of 1/2 hour with a tape speed of 16" per second.

There are no moving parts in the modulating unit. The difficulties of obtaining high frequencies due to the inertia of the cutting stylus in mechanical recording are therefore not present. The system is subject to the same difficulties of eliminating flutter that we find in other methods of recording; however, mechanical vibrations due to the motor and other moving parts of the recording system do not have to be filtered out as is the case with mechanical recording. There are of course no shavings. The recording medium cannot be easily scratched and may be handled in any kind of light and subjected to large variations in temperature. When properly wound on reels it is not liable to breakage or damage during transportation.

LITERATURE

- Stille, K., "Die Electromagnetische Schallaufzeichnung," *E. T. Z.*, 1930, p. 449.
- Hormann, E., "Zur Theorie der Magnetischen Tonaufzeichnung," "On The Theory of Magnetic Sound Recording," *E. N. T.*, Vol. 9, pp. 388-403, Oct., 1932.
- Meyer, E. and Schuller, E., "Magnetische Schallaufzeichnung auf Stählbänder," "Magnetic Sound Recording on Steel Ribbons," *Zeits. f. Techn. Physik*, Vol. 13, No. 12, pp. 593-599, 1932.
- Begun, S., "Die Diktiermaschine im Grossbetrieb," *E. T. Z.*, 1932, p. 204.
- Hickman, C. N., "Delayed Speech," *Bell Labs. Record*, Vol. 11, pp. 308-310, June, 1933.
- "Magnetic Recording and Reproducing," The Marconi-Stille apparatus described, *Wireless World*, Vol. 34, pp. 8-10, Jan. 5, 1934.
- Rust, N. M., "Marconi-Stille Recording and Reproducing Equipment," *Marconi Rev.*, No. 46, pp. 1-11, Jan.-Feb., 1934.
- Frederick, H. A., "Recording and Reproducing Sound," *Rev. Sci. Instruments*, Vol. 5, pp. 177-182, May, 1934.
- Braunmühl, H. J. von, "Magnetische Schallaufzeichnung im Rundfunkbetrieb," "Magnetic Sound Recording in Broadcasting Service," *Funktechnische Monatshefte*, No. 12, pp. 483-486, Dec., 1934.
- Mallina, R. F., "A Mirror for the Voice," *Bell Labs. Record*, Vol. 13, pp. 200-202, Mar., 1935.
- Volk, T., "Magnetophon, ein Neues Tonaufzeichnungsgerät," "Magnetophone, a New Sound Recording Apparatus," *Filmtechnik*, Vol. 11, pp. 229-231, Oct. 26, 1935.
- Hansen, W. H., "Das Magnetophon," "The Magnetophone," *E. T. Z.*, Vol. 56, p. 1232, Nov. 7, 1935.
- Schuller, E., "Magnetische Schallaufzeichnung," "Magnetic Sound Recording," *E. T. Z.*, Vol. 56, pp. 1219-1221, Nov. 7, 1935.
- Schrage, W. F., "Sound Recording on Magnetic Materials," *Radio Craft*, Vol. 7, pp. 537-562, March, 1936.